

MYS INDUCTION HEATING DRIVE

USER GUIDE V1.2

General information

The manufacturer accepts no liability for any consequences resulting from inappropriate, negligent or incorrect installation or adjustment of the optional operating parameters of the equipment or from mismatch in the coil or other mechanic equipments.

The contents of this guide are believed to be correct at the time of printing. In the interest of a commitment to a policy of continuous development and improvement, the manufacturers reserves the right to change the specification of the product or its performance, or the contents of the guide, without notice

All rights reserved. No parts of this guide may be reproduced or transmitted in any form by any means, electrical or mechanical including photocopying, recording or by any information storage or retrieval system, without permission in writing from the publisher.

Please understand the safety precautions before using the product. Before installation, operation, maintenance, inspection, etc. of the heating driver, please read this guide carefully. Please send this guide to end users along with the equipment for their further using this driver.

SERVICE Center Information

For any questions or support, please contact as the following method:

Company: Qingdao Shumu Induction Equipment Co.,Ltd

Add: C25-401,U-Valley,Rd Huaguan 869,High-tech Zone, Qingdao, China266112

Tel: +86-532-89980348

Web: WWW.CMHEAT.COM

Cell: +86-13465321069

Email:SERVICE@CMHEAT.COM

Web:



Wechat:



Whatsapp:



Content

GENERAL INFORMATION	2
CONTENT	3
1 SAFETY INFORMATION	5
1.1 BEFORE INSTALLATION	5
1.2 DURING INSTALLATION	5
1.3 BEFORE TURN ON THE ELECTRIC	6
1.4 AFTER TURNED ON THE ELECTRIC	6
2 PRODUCT INFORMATION	7
2.1 MODEL NUMBER	7
2.2 NAMEPLATE DESCRIPTION-DRIVE IDENTIFICATION	7
2.3 MODEL LIST	8
2.3 PRODUCT SIZE AND MOUNTING HOLE SIZE	9
2.3.1 E61 Series	9
2.3.2 E65 Series	9
2.3.3 E70 Series	10
2.3.4 T70/E70-2L Series	10
2.3.5 S90 Series	11
2.3.6 S100 Series	11
3 MECHANICAL INSTALLATION	12
3.1 PLANNING THE INSTALLATION	12
3.1.1 Access	12
3.1.2 Environmental Protection	12
3.1.3 Cooling	12
3.1.4 Electrical safety	12
3.1.5 Fire protection	12
3.1.6 Hazardous areas	12
3.2 ELECTRICAL INSTALLATION	13
3.2.1 E61 Series Main Circuit Terminals	13
3.2.2 E61 Series Control Terminals and Functions	13
3.2.3 E61 Dial Code Switch Configuration Instructions	14
3.2.4 E65 Series Main Circuit Terminals and Description	14
3.2.5 E70 Series Main Circuit Terminals and Description	15
3.2.6 T70 Series Main Circuit Terminals and Description	16

3.2.7 S90 Series Main Circuit Terminals and Description.	16
3.2.8 S100 Series Main Circuit Terminals and Description.	17
3.2.9 E65/E70/T70/S90/S100 Series Control Terminals and Description.	17
3.3 COIL INSTALLATION.	18
4 UNIVERSAL KEYBOARD OPERATION.	20
4.1 INTERFACE/KEY FUNCTIONS/INDICATOR LIGHT.	20
4.1.1 KEYBOARD INTERFACE.	20
4.1.2 Keys on the keyboard.	20
4.1.3 Indicator light.	21
4.2 MENU DISPLAY MODE.	21
4.3 KEYBOARD OPERATION.	22
4.4 FUNCTION PARAMETER OPERATION.	23
4.5 MONITORING PARAMETER OPERATION.	24
4.6 USER'S PASSWORD INPUT.	25
4.7 LIMIT THE POWER WITH KEYBOARD.	25
5 PARAMETER DESCRIPTION.	26
5.1 FUNCTIONAL PARAMETERS.	26
5.2 FUNCTIONAL PARAMETERS LIST.	27
5.3.1 F0 Loop Control.	27
5.3.2 F1 Input/Output Terminal.	28
5.3.3 F2 Setting.	30
5.3.4 F3 Setting.	31
5.3.5 F5 Communication Protocol.	31
5.3 MONITORING PARAMETERS LIST.	32
6 OPERATION CONTROL.	33
6.1 CONTROL MODE LIST.	33
6.1.1 Adjust the power Level by Keyboard.	33
6.1.2 X Terminal Startup, Adjust the power Level by Keyboard.	33
6.1.3 Adjust the power level by X TERMINAL.	33
6.1.4 Adjust the power by Potentiometer/Adjust the power by Analog Value.	33
6.1.5 X Terminal Startup, Adjust the power by Analog Value.	33
7 FAULT DIAGNOSIS AND COUNTERMEASURES.	34
7.1 ERROR CODE AND DESCRIPTION.	34
7.2 FAQ AND TROUBLESHOOT.	39
8 ATTACHED TABLE FOR RECORDING REAL-TIME OPERATION DATA OF INDUCTION DRIVE.	41

1 Safety information

Warnings, Cautions and Notes



Electric shock risk



Caution: A caution contains information which is necessary for avoiding a risk of damage to the product or other equipment.



Warning: A warning contains information which is essential for avoiding a safety hazard.

Note: A note contains information which helps to ensure correct operation of the product.

1.1 Before Installation



Warning

When the Drive is found to be flooded, any parts missing or damaged, please do not install it.

If the product can not match the packing list, please do not install it.



Caution

Handle gently to avoid the risk of damage to the Drive.

Do not use damaged drives or the drive with any parts missing. It may have a risk of injury.

Do not touch the components of the drive by hand, The drive maybe damaged by static electricity

1.2 During Installation



Warning

Please install on flame retardant objects such as metal cabinet, Install and keep the cabinet away from combustible materials. Otherwise it may cause fire.

Do not unscrew the fixed bolts of equipment components, especially those with red marks.



Caution

Do not allow cable heads, connectors or screws to fall into the drive. It may cause the drive damage.

When two or more drives are installed in the same cabinet, please pay attention to the installation position and space to ensure the cooling effect.

1.3 Before Turn on the Electric



Warning

The drive must be covered before it is connected to the power. Otherwise you might get an electric shock.

All connections of other equipments' components must follow the instructions of this guide, and the wiring should be connected according to the circuit connection which provided in this Guide.

Note

Make sure the voltage rating of the input power supply is the same as the rated voltage rating of the Drive.

Please check the wiring position on input terminals (R, S, T) and output terminals (L1,L2) of the power supply is correct

Check the driver connected to the peripheral circuit whether there is a short circuit phenomenon, Please make sure all connected circuit are tight, otherwise cause damage to the Drive.

1.4 After Turned on the Electric



Electric shock risk

Do not arbitrarily change the drive manufacturer's parameters. Otherwise it may cause damage to the equipment.

Do not open the cover plate after power on. Danger of electric shock.

Do not touch any input/output terminals of the drive. Danger of electric shock.

2 Product Information

2.1 Model Number

The way in which the model numbers for the Drives are formed is illustrated below

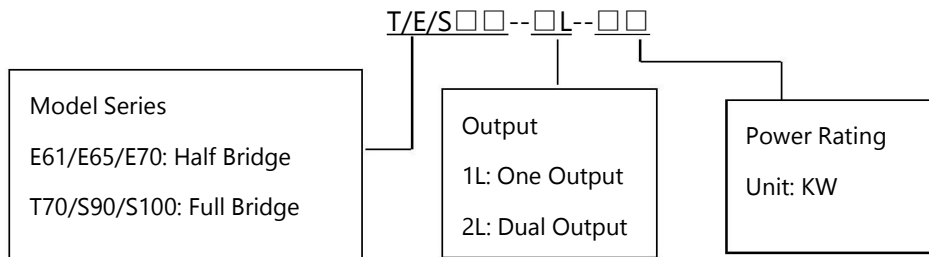

Figure 2-1 Model Number

2.2 Nameplate description-drive identification

This drive label is found on the side of the Drive.

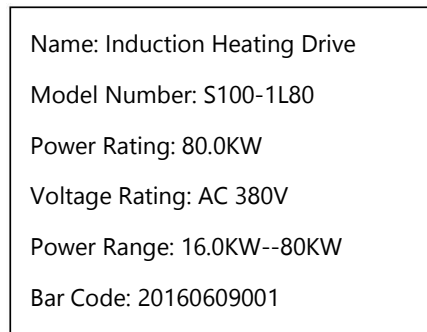

Figure 2-2 Typical Drive nameplate

2.3 Model List

Mode Series	Model Number	Power Rating (KW)	Voltage Rating (V)	Output current Rating	Output Power levels	Inductance (1KμH)	Power Range (KW)	Heating Distance (CM)
E61	E61-1L05	5	380V AC	20	6	190-200uH	1-5	1.5-3
	E61-1L06	6	380V AC	25	6	180-190uH	1.2-6	1.5-3
E65	E65-1L8	8	380V AC	35	8	140-150	1.6-8	1.5-3
	E65-1L10	10	380V AC	45	10	120-130	2-10	1.5-3
	E65-2L06	2*6	380V AC	25	6	160-170	Each1.2-6	1.5-3
E70	E70-1L12	12	380V AC	70	12	110-120	2.4-12	1.5-3
	E70-1L15	15	380V AC	80	16	100-100	3-15	1.5-3
	E70-1L20	20	380V AC	100	25	80-90	4-20	1.5-3
	E70-2L08	2*8	380V AC	45	8	140-150	Each1.6-8	1.5-3
	E70-2L12	2*12	380V AC	80	12	110-120	Each2.4-12	1.5-3
	E70-2L15	2*15	380V AC	100	16	100-100	Each3-15	1.5-3
	E70-1L25	25	380V AC	110	35	70-80	5-25	1.5-3
	E70-1L30	30	380V AC	120	35	70-80	6-30	1.5-3
T70	T70-1L20	20	380V AC	55	12	230-240	4-20	1.5-3
	T70-1L25	25	380V AC	75	16	190-200	5-25	1.5-3
	T70-1L30	30	380V AC	80	16	190-200	6-30	1.5-3
S90	S90-1L40	40	380V AC	105	25	170-180	8-40	1.5-3
	S90-1L50	50	380V AC	130	25	150-160	10-50	1.5-3
	S90-1L60	60	380V AC	140	35	140-150	12-60	1.5-3
S100	S100-1L80	80	380V AC	200	50	110-120	16-80	1.5-3
	S100-1L90	90	380V AC	230	60	90-95	18-90	1.5-3
	S100-1L100	100	380V AC	250	70	85-90	20-100	1.5-3

Note:

Heating distance is different with different applications; please select the right distance as per detailed application.

Call service center for the support is necessary.

For normal application, please select 2-3cm, please refer chapter 3.3 coil installation

2.3 Product Size and Mounting Hole Size

2.3.1 E61 Series

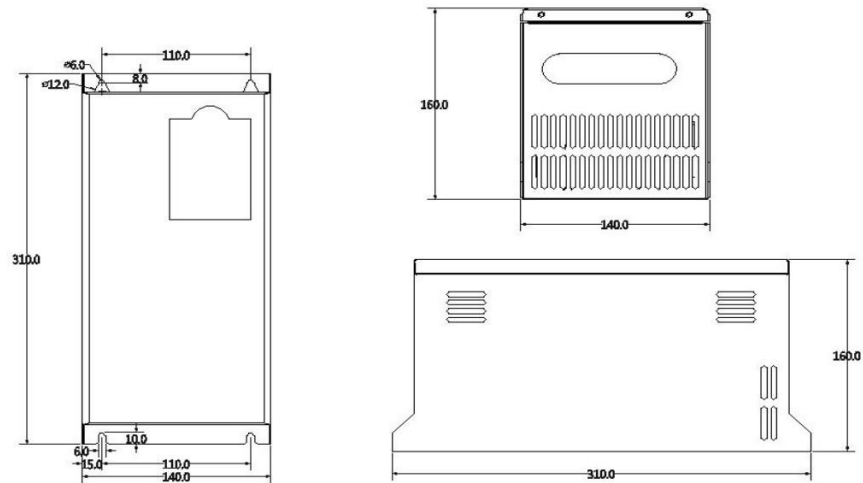

Figure 2-3 Size of E61 Series

2.3.2 E65 Series

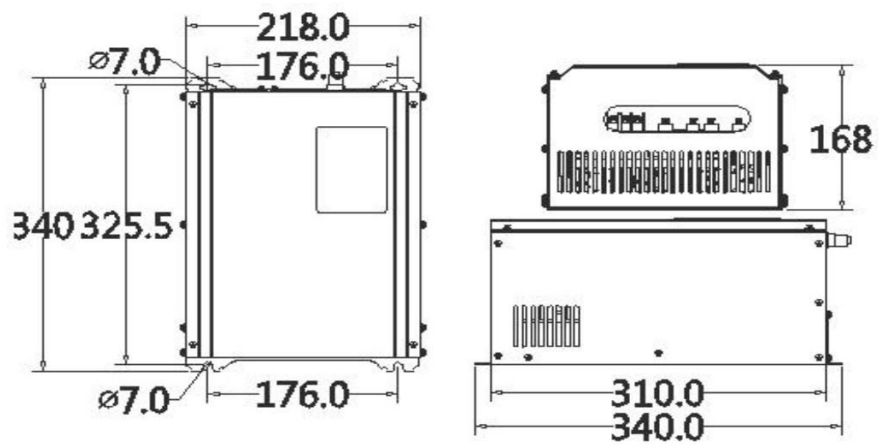

Figure 2-4 Size of E65 Series

2.3.3 E70 Series

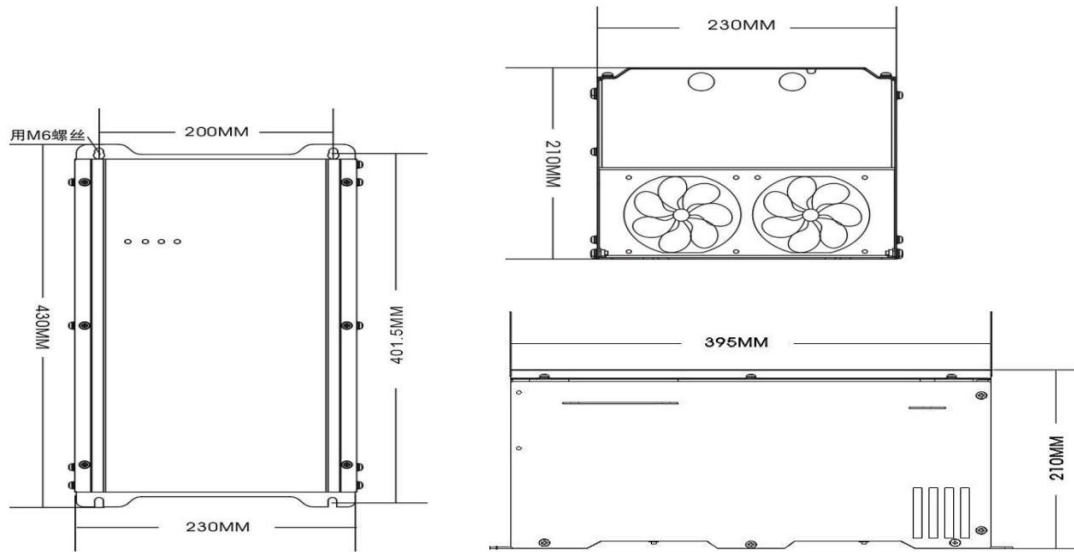

Figure 2-5 Size of E70 Series

2.3.4 T70/E70-2L Series

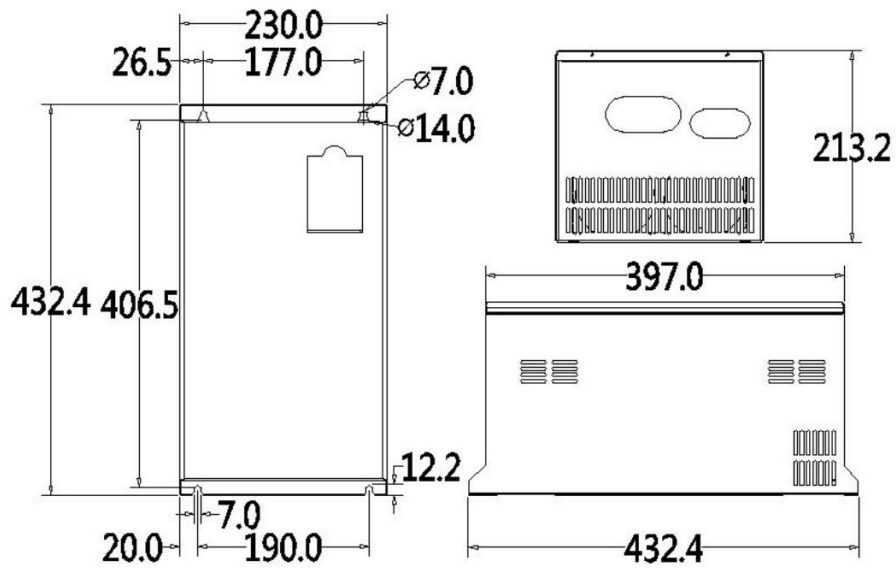

Figure 2-6 Size of E70-2L Series&T70 series

2.3.5 S90 Series

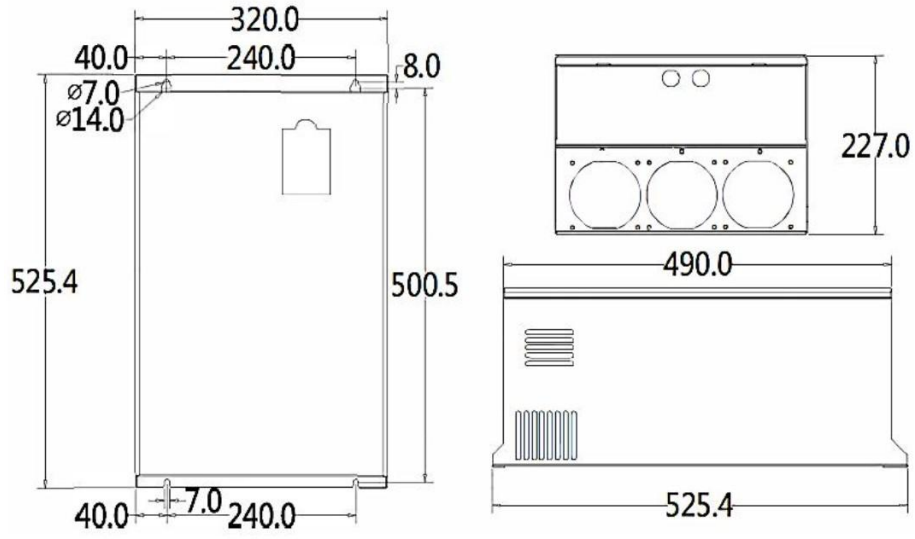

Figure 2-7 Size of S90 Series

2.3.6 S100 Series

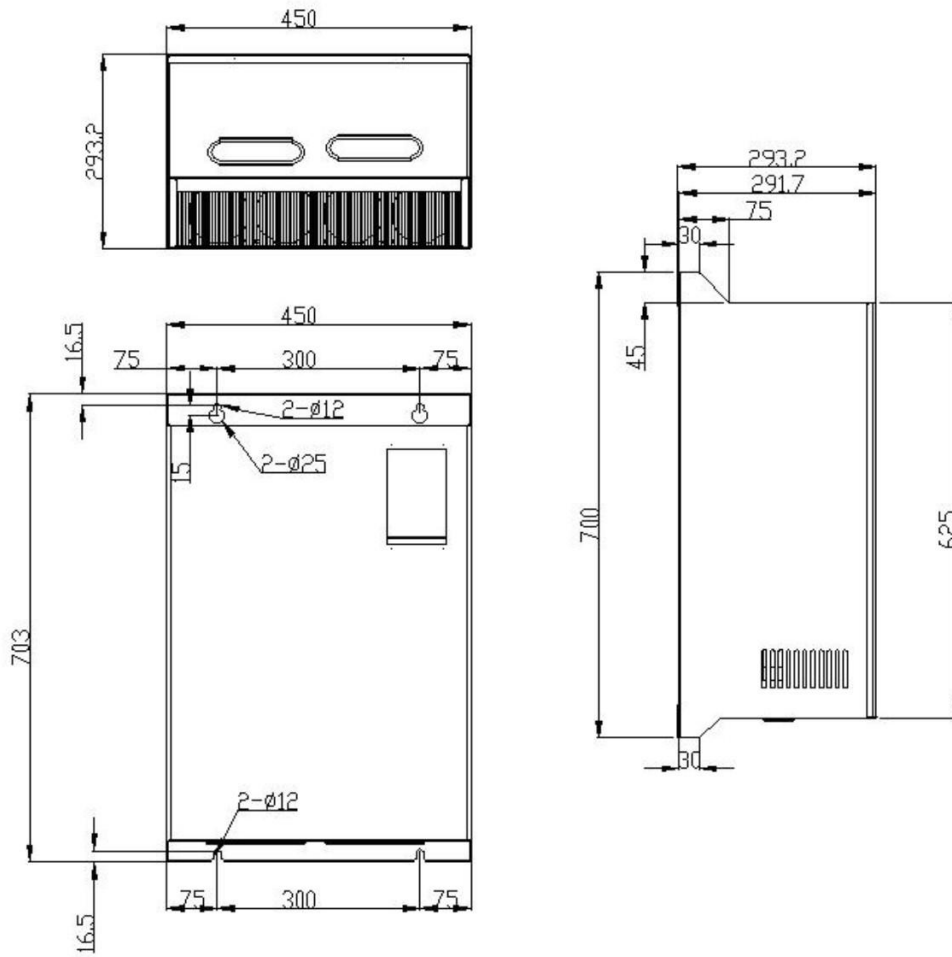

Figure 2-8 Size of S90 Series

3 Mechanical Installation

3.1 Planning the installation

3.1.1 Access

Access must be restricted to authorized personnel only. Safety regulations which apply at the place of use must be complied with.

3.1.2 Environmental Protection

The drive must be protected from:

Moisture, including dripping water or spraying water and condensation. An anti-condensation heater may be required, which must be switched off when the drive is running.

Contamination with electrically conductive material.

Contamination with any form of dust which may restrict the fan, or impair airflow over various components.

Temperature beyond the specified operation and storage ranges between $-10^{\circ}\text{C} \sim 40^{\circ}\text{C}$

Please install in the place where there is no vibration or vibration should not be greater than 0.6g.

3.1.3 Cooling

The heat produced by the drive must be removed without its specified operating temperature being exceeded. Note that a sealed enclosure gives much reduced cooling compared with a ventilated one, and may need to be larger and/or use internal air circulating fans.

3.1.4 Electrical safety

The installation must be safe under normal and fault conditions. Electrical installation instructions are given in chapter 3.2. Electrical Installation.

3.1.5 Fire protection

The drive enclosure is not classified as a fire enclosure, A separate fire enclosure must be provided.

3.1.6 Hazardous areas

The drive must be located in classified hazardous areas unless it is installed in an approved enclosure and the installation is certified.

3.2 Electrical Installation

3.2.1 E61 Series Main Circuit Terminals

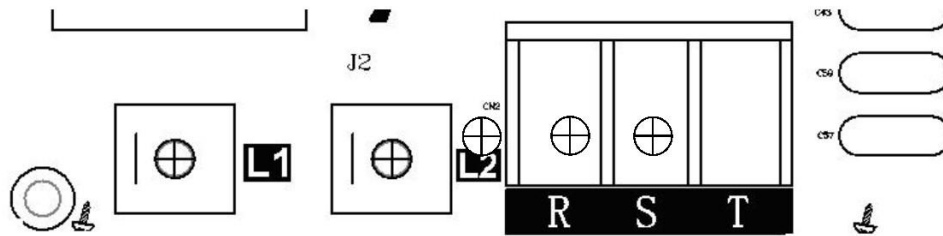

Figure 3-1 E61 Main Circuit Terminals

Terminal Mark	Description	Function
R、S、T	3-phase power input terminal	AC Input 3-phase Power Connection
L1,L2	Induction Heating Drive output	Coil connections. Irrespective of positive and negative

3.2.2 E61 Series Control Terminals and Functions

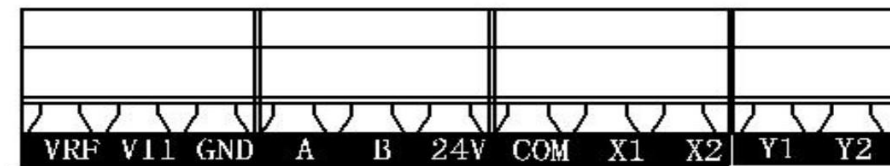

Figure 3-2 E61 Control terminals

Item	Terminal	Description	Function
Power	VRF-GND	+5V power supply for external electrics	Provide +5V power supply for external potentiometer. Potentiometer Value Range: 1K-100K
Analog Input	VI1- GND	Input voltage: 0-10V Input Current: 4-20mA	When select 4-20mA control mode, please switch bit 4 on S1 dial code switch to position ON
Communication	A - B	RS-485 Port	485 Communication
Power	24V - COM	+24V Power Supply	Provide +24V power supply to External electrical , Max current totally : 100mA
Digital Input	X1 - COM	Input digital signal (programmable)	Equipment ON/OFF
Digital Input	X2 - COM	Input digital signal (programmable)	Equipment ON/OFF / External Fault Input
Digital Output	Y1 - COM	Output digital signal (programmable)	Output Voltage:+24V; Maximum Current :20mA
Digital Output	Y2 - COM	Output digital signal (programmable)	Output Voltage:+24V; Maximum Current :20mA

3.2.3 E61 Dial Code Switch Configuration Instructions

Configure the Dial Code Switch S1 according to the communication function and control mode

RS 485 Function: Switch on the bit 1 on S1 to Position ON

0-10V Control Method: Switch off the bit 4 on S1

0-20mA Control Method: Switch on the bit 4 on S1 to Position ON

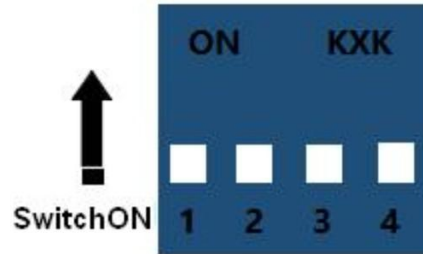

Figure 3-3 E61 Dial Code Switch S1

3.2.4 E65 Series Main Circuit Terminals and Description

(1) Main Circuit Terminal & Description for E65 Dual Circuit Series

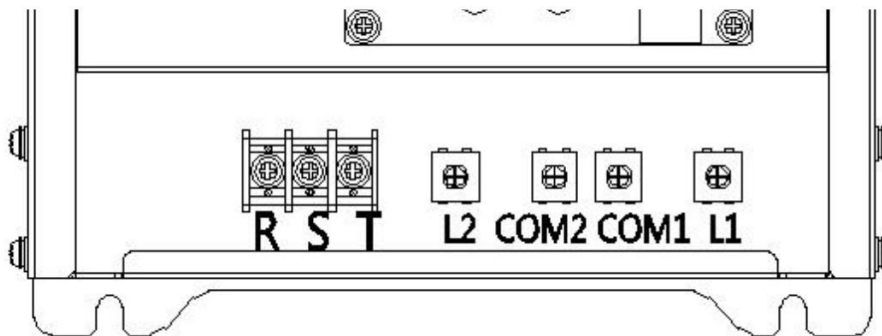

Figure 3-4 E65 Dual Circuit- Main Circuit Terminals

Terminal Mark	Description	Function
R、 S、 T	3-phase power input terminal	AC Input 3-phase Power Connection
L1,COM1	Circuit 1 Heating Drive output terminal	Coil 1 Connection. Irrespective of positive and negative
L2,COM2	Circuit 2 Heating Drive output terminal	Coil 2 Connections. Irrespective of positive and

(2) Main Circuit Terminal & Description for E65 Single Circuit Series

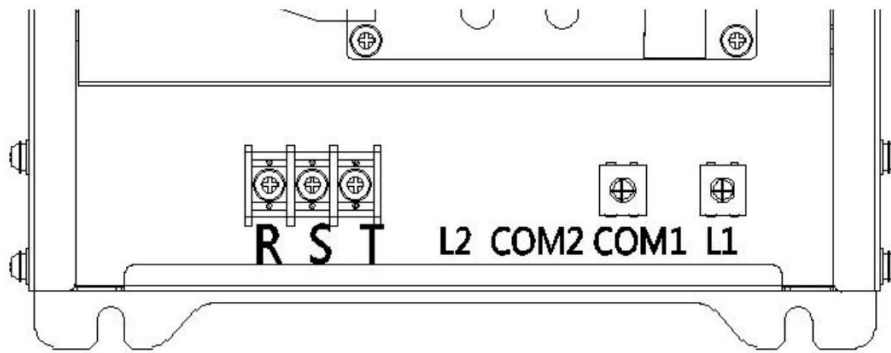

Figure 3-5 E65 Single Circuit- Main Circuit Terminals

Terminal Mark	Description	Function
R、 S、 T	3-phase power input terminal	AC Input 3-phase Power Connection
L1,COM1	Induction Heating Drive output	Coil connections. Irrespective of positive and negative

3.2.5 E70 Series Main Circuit Terminals and Description

(1) Main Circuit Terminal & Description for E70Dual Circuit Series

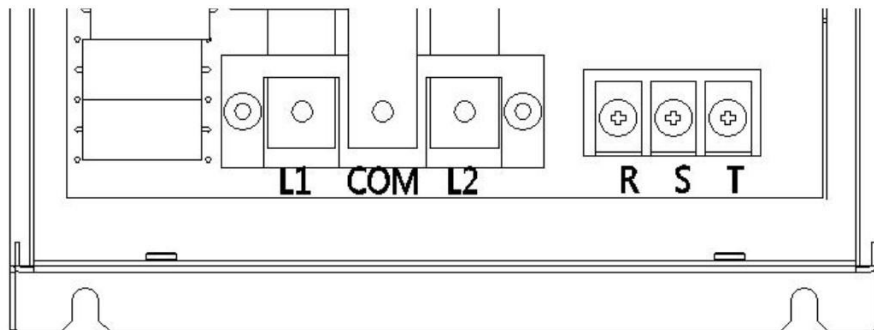

Figure 3-6 E70 Dual Circuit- Main Circuit Terminals

Terminal Mark	Description	Function
R、 S、 T	3-phase power input terminal	AC Input 3-phase Power Connection
L1,COM	Circuit 1 Heating Drive output terminal	Coil 1 Connection. Irrespective of positive and negative
L2,COM	Circuit 2 Heating Drive output terminal	Coil 2 Connections. Irrespective of positive and

(2) Main Circuit Terminal & Description for E70 Single Circuit Series

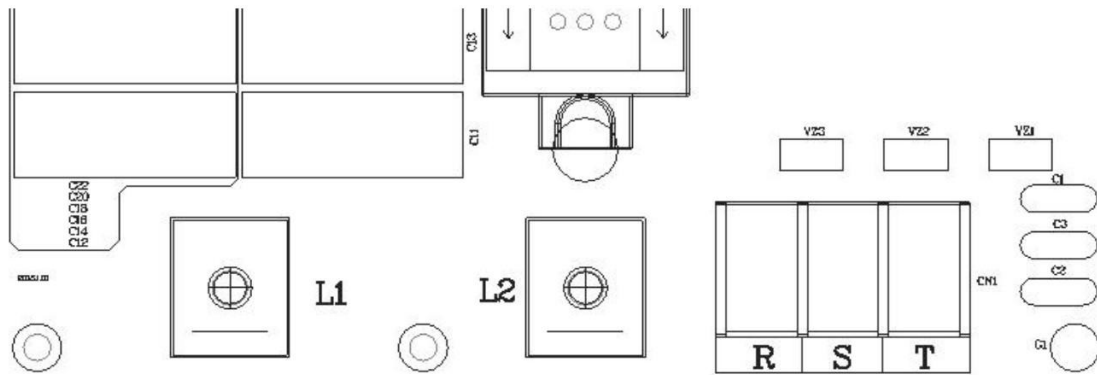

Figure 3-7 E70 Single Circuit- Main Circuit Terminals

Terminal Mark	Description	Function
R、 S、 T	3-phase power input terminal	AC Input 3-phase Power Connection
L1,L2	Induction Heating Drive output	Coil connections. Irrespective of positive and negative

3.2.6 T70 Series Main Circuit Terminals and Description

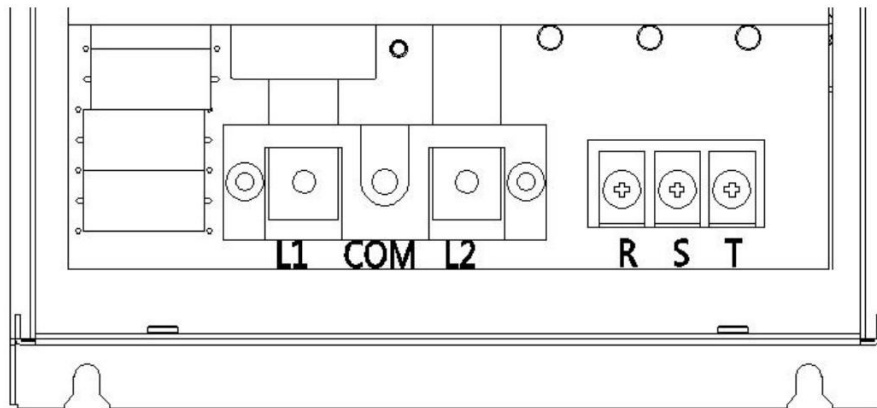

Figure 3-8 T70 Main Circuit Terminals

Terminal Mark	Description	Function
R、 S、 T	3-phase power input terminal	AC Input 3-phase Power Connection
L1,L2	Induction Heating Drive output	Coil connections. Irrespective of positive and negative

3.2.7 S90 Series Main Circuit Terminals and Description

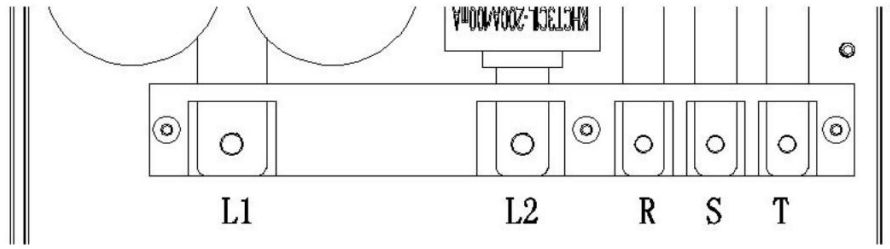

Figure 3-9 S90 Main Circuit Terminals

Terminal Mark	Description	Function
R、S、T	3-phase power input terminal	AC Input 3-phase Power Connection
L1,L2	Induction Heating Drive output	Coil connections. Irrespective of positive and negative

3.2.8 S100 Series Main Circuit Terminals and Description

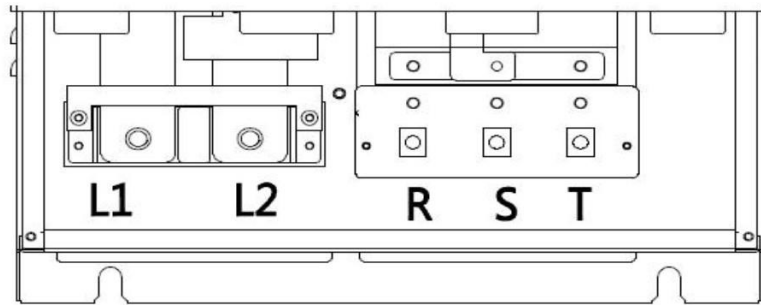

Figure 3-10 S90 Main Circuit Terminals

Terminal Mark	Description	Function
R、S、T	3-phase power input terminal	AC Input 3-phase Power Connection
L1,L2	Induction Heating Drive output	Coil connections. Irrespective of positive and negative

3.2.9 E65/E70/T70/S90/S100 Series Control Terminals and Description

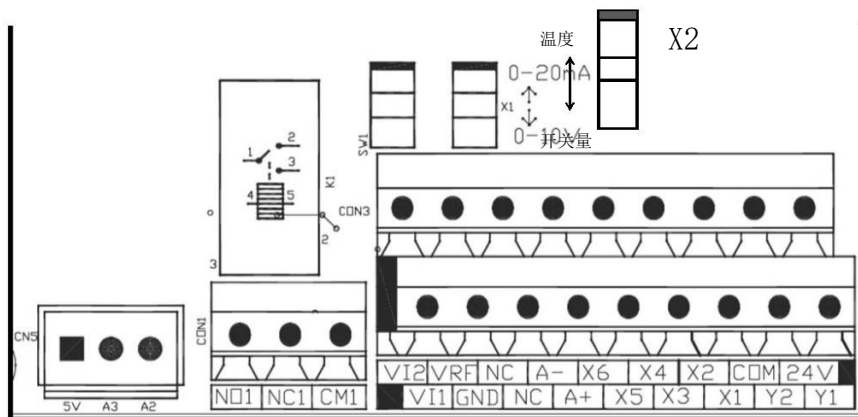

Figure 3-11 S90 Control Interface

Item	Terminal	Description	Function
Power	VRF-GND	+5V power supply for external electrics	Provide +5V power supply for external potentiometer. Potentiometer Value Range: 1K-100K
Analog Input	VI1- GND	Input voltage: 0-10V Input Current: 4-20mA	When select 4-20mA control mode, please switch S1 dial code switch to position 0-20MA
Analog Input	VI2- GND	Input voltage: 0-10V Input Current: 4-20mA	When select 4-20mA control mode, please switch S1 dial code switch to position 0-20MA
Communication	A+ - A-	RS-485 Port	485 Communication Function
Power	24V - COM	+24V Power Supply	Provide +24V power supply to External electrical , Max current totally : 100mA
Digital Input	X1 - COM	Input digital signal (programmable)	Equipment ON/OFF (Power Level P1)
Digital Input	X2 - COM	Input digital signal (programmable)	Equipment ON/OFF (Power Level P2)/Test Coil Temperature. Switch the functions with the code switch X2 as shown on Figure 3-10 S90 Control Interface
Digital Input	X3 - COM	Input digital signal (programmable)	Equipment ON/OFF (Power Level P3)
Digital Input	X4- COM	Input digital signal (programmable)	Equipment ON/OFF (Power Level P4)
Digital Input	X5- COM	Input digital signal (programmable)	Equipment ON/OFF (Power Level P5)
Digital Input	X6- COM	Input digital signal (programmable)	Equipment ON/OFF (Power Level P6)
Digital Output	Y1 - COM	Output digital signal (programmable)Heating/Fault	Output Voltage:+24V; Maximum Current :20mA Y1-COM: Fault Status Output
Digital Output	Y2 - COM	Output digital signal (programmable)Heating/Fault	Output Voltage:+24V; Maximum Current :20mA Y2-COM: Heating Status Output
Relay Output	CM1-NO1	Relay always ON	Fault Relay Output 220VAC/2A
Relay Output	CM1-NC1	Relay always OFF	
Temperature Testing	CN5	Outside Temperature testing	Generally used to check the temperature of the coil, NTC Thermistor : 100K,B value =3950

3.3 Coil Installation

Please find the corresponding model on the nameplate on the side of the drive, and make the corresponding coil that meets the requirements of inductance according to the wire diameter indicated in the following table.:

Inductance measurement: Level 1K on digital bridge, heating material is iron, and heating distance is 2-3 cm.

Different heating materials, different heating distance, the optimal inductance changes, please design the best coil according to applications.

All inductance values indicated are normal temperature loaded heating materials. Inductance values changes with different heating material and cable temperature.

Series	Model	Power : KW	Input Current: A	Inductance: 1K μ H	Cable size for Output Coil : mm ²	Frequency Range: KHz	Thickness of Insulation Cotton: mm
E61	E61-1L05	5	7.5	180	6	8-35	20-30
	E61-1L06	6	9	160	6	8-35	20-30
E65	E65-2L06	6*2	18	160	6	8-35	20-30
	E65-1L08	8	12	140	8	8-35	20-30
	E65-1L10	10	15	120	10	8-35	20-30
E70	E70-2L08	8*2	24	140	8	8-35	20-30
	E70-1L12	12	18	110	12	8-35	20-30
	E70-2L12	12*2	36	110	12	8-35	20-30
	E70-1L15	15	22.5	100	16	8-35	20-30
	E70-2L15	15*2	45	100	16	8-35	20-30
	E70-1L20	20	30	85	25	8-35	20-30
	E70-1L30	30	45	75	35	8-35	20-30
T70	T70-1L20	20	30	240	12	8-35	20-30
	T70-1L30	30	45	200	16	8-35	20-30
S90	S90-1L30	30	45	200	16	8-35	20-30
	S90-1L40	40	60	180	25	8-35	20-30
	S90-1L50	50	75	160	25	8-35	20-30
	S90-1L60	60	90	140	35	8-35	20-30
S100	S100-1L80	80	120	120	50	8-35	20-30
	S100-1L100	100	150	110	70	8-35	20-30

Note:

Coil installation must be well ventilated with good heat emission;

The Distance from any Coil cable to any material which can be induction heated or any metals should farer then 7cm;

The distance between two coils should at least 20cm

4 Universal Keyboard Operation

4.1 Interface/Key functions/Indicator light

4.1.1 Keyboard Interface

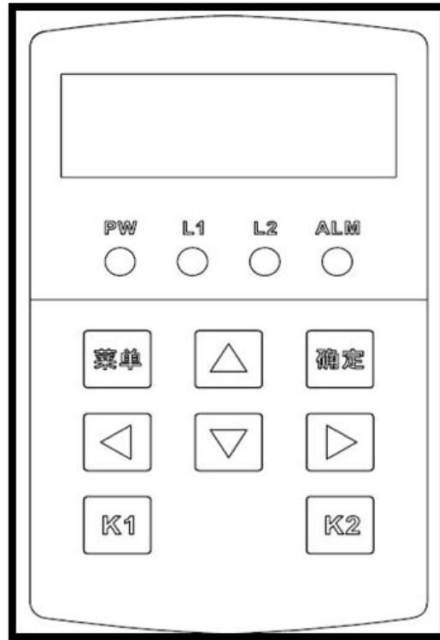

4.1.2 Keys on the keyboard

Key	Name	Description
	Program Key	Level menu toggle, or exit
	Enter Key	Enter the menu, set parameters and confirm
	Up key	Data, long press for fast increase
	Down key	Data and function code decrease, long press for fast decrease
	Move to left	Function code increase by group
	Move to right	Function code decrease by group
	Reserved	Extend user-defined functionality
	Reserved	Extend user-defined functionality

4.1.3 Indicator light







Mark	Name	Description
PW	Power Indicator	This light on means voltage is normal, if voltage too low, this light is off
L1	L1 Heating indicator	Always on means the drive is heating, shinning means no load detected
L2	L2 Heating indicator	-----
ALM	Alarm Indicator	Some fault in the machine

4.2 Menu Display mode

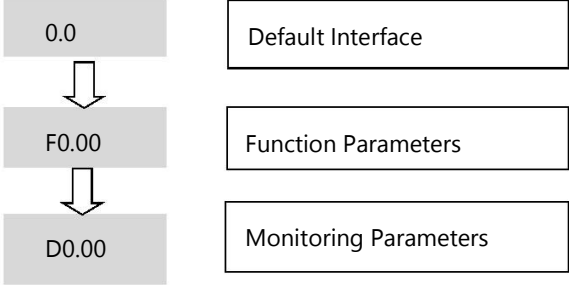
There are three modes in menu, and each mode has two levels

Mode	Level 1 Menu	Level 2 Menu
Parameter	Fx.xx: Function Parameter. The corresponding Function parameter can be set by Up Key or Down Key. Press the Enter Key to enter the second-level display of this parameter	Display the values of the corresponding parameters, change the corresponding parameters by pressing up and down keys, press the Enter key to save the modification results, and press the green Program Key to abandon the modification and exit.
Monitoring	Dx.xx: Monitoring parameter. The corresponding monitoring number can be set by Up Key or Down Key. Press the Enter Key to enter the second-level display of this parameter	Monitor the corresponding values
Default	Display input current	
Power Level	P0-P6, Adjust levels by increase or decrease key	

4.3 Keyboard operation

Key	Name	Function & Description
	Program Key	<p>Switch among power display, Function Parameters and Monitoring Parameters</p>  <p>Note: the main interface is displayed by default. When there is no key operation in the non-main interface, it will automatically return to the main interface to display the input current as default.</p>
	Enter Key	Enter the monitoring parameter interface or function parameter value setting interface from the menu, and complete the modification of function parameters by press the red Enter Key
	Up / Down Key	Increase/decrease. When press these two keys, Function parameters can be add or deduct 1.
	Move to right/Left key	Customer can change the parameter from both sides one by one. Eg. Move to right key, when customer press this key first time, the left digital figure will start shinning, then from left to right by order.
	Reserved	Extend user-defined functionality
	Reserved	Extend user-defined functionality

4.4 Function parameter operation

(1) Function Parameter level menu increase/decrease, as shown in the figure below:

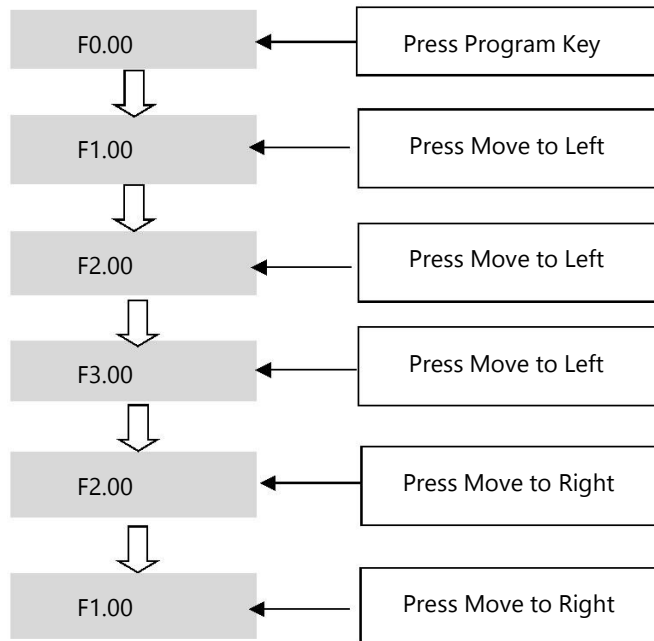

(2) Function parameter value setting interface, as shown in the figure below: change the parameter value of F1.01 from 6 to 7

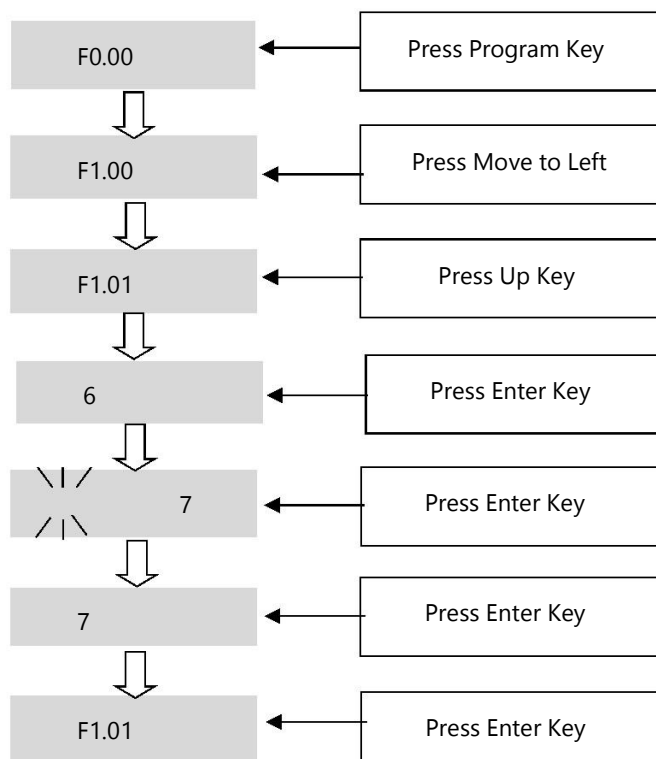

4.5 Monitoring parameter operation

Monitoring parameter level menu increase/decrease, as shown in the following figure:

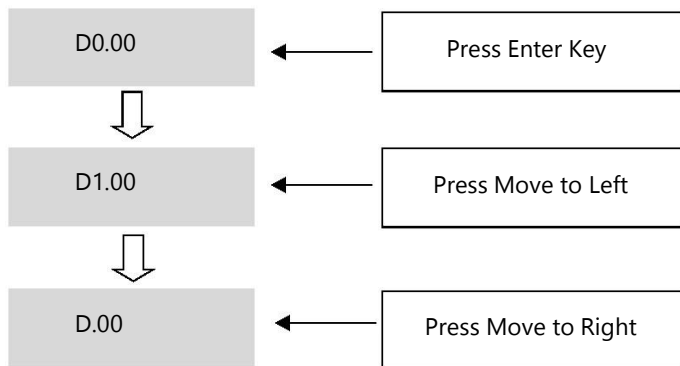

How to check the Monitoring parameter eg D001? Please see the following figure:

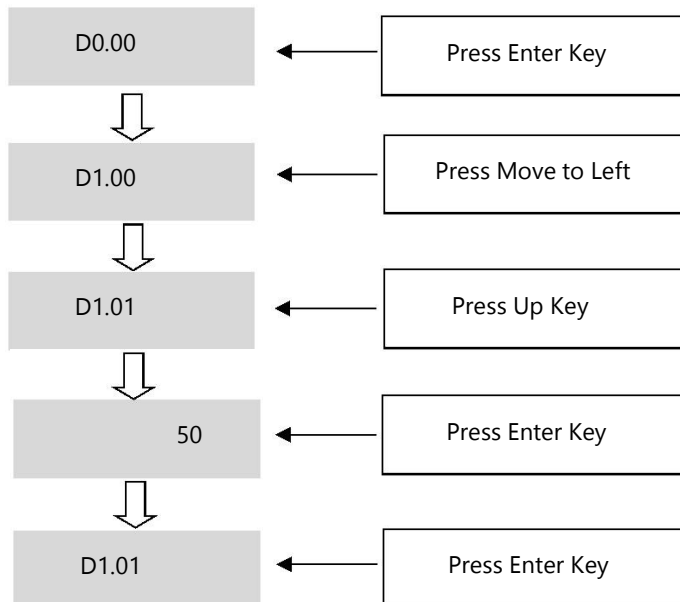

4.6 User's Password Input

Without password you can check F0.XX,F1.XX,F2.XX. Please enter password for the parameter of F0.XX,F1.XX,F2.XX ,F3.XX,F4.XX,F5.XX. Password is different with different software version. Please get the software version by checking D011 parameter.

- (1) For software 959, 1169 and 1186, please input 3011 in F3.01
- (2) For software 1311 and 1360, please input 3011 in F0.00
- (3) For software 1729, 1783 or figure bigger then 1783, please enter 6375 in F0.00

How to input password? Please check the following example:

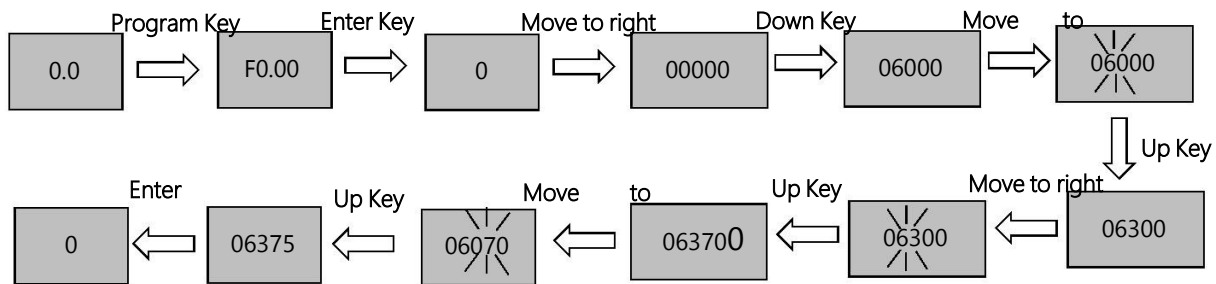

4.7 Limit the Power with Keyboard

1. Input the password to unlock the keyboard parameter protection

How to input password please refer charter 4.6 User's Password Input

2. Press the Program Key, you can see F0.00

3. Change power of p1, method as follow:

Change F0.00 to F0.05 by the Up/Down Key, press Enter Key. Then you can see 20, please change 20 into 20*(target power/Rating power), press Enter Key to Save the change..

4. Change power of p2, method as follow:

Change F0.05 to F0.06 by the Up/Down Key, press Enter Key. Then you can see 40, please change 40 into 40*(target power/Rating power), press Enter Key to Save the change..

5. Change power of p3, method as follow:

Change F0.06 to F0.07 by the Up/Down Key, press Enter Key. Then you can see 60, please change 60 into 60*(target power/Rating power), press Enter Key to Save the change.

6. Change power of p4, method as follow:

Change F0.07 to F0.08 by the Up/Down Key, press Enter Key. Then you can see 75, please change 75 into 80*(target power/Rating power), press Enter Key to Save the change.

7. Change power of p5, method as follow:

Change F0.08 to F0.09 by the Up/Down Key, press Enter Key. Then you can see 80, please change 80 into $100 \times (\text{target power} / \text{Rating power})$, press Enter Key to Save the change.

8. Change power of p6, method as follow:

Change F0.09 to F0.10 by the Up/Down Key, press Enter Key. Then you can see 100, please change 100 into $100 \times (\text{target power} / \text{Rating power})$, press Enter Key to Save the change.

9. Power off the Drive and Turn on again, and then power changed.

Note: Users also can set each Level's Power by Custom choice.

5 Parameter description

5.1 Functional Parameters

Code	Description	Unit	Note
F0.01	Power Adjustment Mode configuration		F0.01=2.02 Potentiometer regulating power/analog regulating power; F0.01=15.15 Keyboard regulating power (P0--P6) F0.01=0.00 X Terminal regulating power F0.01=0.02 X Terminal start the machine and analog regulating power
F0.11	Maximum output current	A	
F2.09	Output frequency lower limit	KHz	
F2.10	Output frequency upper limit	KHz	

5.2 Functional Parameters List



Warning

The parameters have been carefully configured before delivery. Users do not need to change the Settings. Please do not enter the parameter mode to modify any parameters.

5.3.1 F0 Loop Control

Function Parameter	Name	Setting	Unit	Default
F0.00	Heating Mode	0: Normal 1: Reserved	1	0
F0.01	L1 Power selection	Integer Place—ON/OFF control:		0.00
		0.xx: Terminal Control (CH-1) 1.xx: Terminal Control (CH-2) 2.xx~3.xx: Reserved 4.xx: Communication Level Command(NET-1) 5.xx: Communication Level Command(NET-2) 6.xx: Communication Set Power(NET-1) 7.xx: Communication Set Power(NET-2) 8.xx~15.xx: Reserved		
F0.02	Reserved		1	1
F0.03	Digital Power Setting 1	5.0%~100.0%	0.1%	80.0%
F0.04	Digital Power Setting 2	5.0%~100.0%	0.1%	80.0%
F0.05	Power Setting 1	5.0%~100.0%	0.1%	20.0%
F0.06	Power Setting 2	5.0%~100.0%	0.1%	40.0%
F0.07	Power Setting 3	5.0%~100.0%	0.1%	60.0%
F0.08	Power Setting 4	5.0%~100.0%	0.1%	75.0%
F0.09	Power Setting 5	5.0%~100.0%	0.1%	80.0%
F0.10	Power Setting 6	5.0%~100.0%	0.1%	100.0%
F0.11	Reserved			

5.3.2 F1 Input/Output Terminal

Function Parameter	Name	Setting	Unit	Default
F1.00	Input Terminal X1 Function	0: Free 1: Stop Heating(CH-1)	1	5
F1.01	Input Terminal X2 Function	2: Stop Heating (CH-2) 3: Heating(default power,CH-1)	1	6
F1.02	Input Terminal X3 Function	4: Heating (default power, CH-2) 5: Heating (Level P1,CH-1) 6: Heating(Level P2,CH-1)	1	7
F1.03	Input Terminal X4 Function	7: Heating(Level P3,CH-1) 8: Heating(Level P4,CH-1) 9: Heating(Level P5,CH-1) 10: Heating(Level P6,CH-1)	1	8
F1.04	Input Terminal X5 Function	11: Heating(Level P1,CH-2) 12: Heating(Level P2,CH-2) 13: Heating(Level P3,CH-2) 14: Heating(Level P4,CH-2)	1	9
F1.05	Input Terminal X6 Function	15: Heating(Level P5,CH-2) 16: Heating(Level P6,CH-2) 17: Level Selection Terminal1(CH-1)	1	10
F1.06	Reserved	18: Level Selection Terminal2(CH-1) 19: Level Selection Terminal3(CH-1)	1	0
F1.07	Reserved	20: Level Selection Terminal1(CH-2) 21: Level Selection Terminal2(CH-2) 22: Level Selection Terminal3(CH-2)	1	0
F1.08	Terminal filter Times	23: Increase Power(CH-1) 24: Decrease Power(CH-1)	1	5
F1.09	Reserved	25: Increase Power(CH-2) 26: Decrease Power(CH-2)	-	-
F1.10	AI1 Lower limits	27: External fault 28: Fault Reset	0.01V	0.00V
F1.11	AI1 Lower limits Setting	0~10	0.1%	0.0%
F1.12	AI1 Upper limits	-	0.01V	10.00V
F1.13	AI1 Upper limits Setting	0.00~10.00V	0.1%	100.0%
F1.14	AI1 Input Filter Time	0.0%~100.0%	0.01s	0.10s
F1.15	AI2 Lower limits	0.00~10.00s	0.01V	0.00V
F1.16	AI2 Lower limits Setting	0.00~10.00V	0.1%	0.0%
F1.17	AI2 Upper limits	0.0%~100.0%	0.01V	10.00V
F1.18	AI2 Upper limits Setting	0.00~10.00V	0.1%	100.0%
F1.19	AI2 Input Filter Time	0.0%~100.0%	0.01s	0.10s
F1.20	Relay 1 Output Function Selection	0: Free	1	4
F1.21	Relay 2 Output Function Selection	1: Undervoltage	1	0
F1.22	Y1 Terminal Function Selection	2: Heating Status(A) 3: Heating Status(B)	1	6
F1.23	Y2 Terminal Function Selection	4: Fault 5: Fan Running	1	0
F1.24	Reserved	6: Fault Information	-	-

Function Parameter	Name	Setting	Unit	Default
F1.25	Reserved	-	-	-
F1.26	Reserved	-	-	-
F1.27	Reserved	-	-	-
F1.24	Reserved	-	-	-
F1.25	Reserved	-	-	-
F1.26	Reserved	-	-	-
F1.27	Reserved	-	-	-
F1.28	AO1 Output selection	0: Free 2: Output Power(B) 4: Power Setting(B) 6: Coil Current(B) 8: Temp of Radiator 10: AI2 Input Value 12: Output Frequency(B) 1: Output Power(A) 3: Power Setting(A) 5: Coil Current(A) 7: BUS Voltage 9: AI1 Input Value 11: Output Frequency(A)	1	11
F1.29	AO1 Output lower limits	0.0% ~ 100.0%	0.1%	0.0%
F1.30	Lower limits corresponds to AO1 output	0.00 ~ 10.00V	0.01V	8.50V
F1.31	AO1 Output upper limits	0.0% ~ 100.0%	0.1%	100.0%
F1.32	Upper limits corresponds to AO1 output	0.00 ~ 10.00V	0.01V	3.00V
F1.33	AO2 Output selection	0: Free 2: Output Power(B) 4: Power Setting(B) 6: Coil Current(B) 8: Temp of Radiator 10: AI2 Input Value 12: Output Frequency(B) 1: Output Power(A) 3: Power Setting(A) 5: Coil Current(A) 7: BUS Voltage 9: AI1 Input Value 11: Output Frequency(A)	1	12
F1.34	AO2 Output lower limits	0.0% ~ 100.0%	0.1%	0.0%
F1.35	Lower limits corresponds to AO2 output	0.00 ~ 10.00V	0.01V	8.50V
F1.36	AO2 Output upper limits	0.0% ~ 100.0%	0.1%	100.0%
F1.37	Upper limits corresponds to AO2 output	0.00 ~ 10.00V	0.01V	3.00V

5.3.3 F2 Setting

Function Parameter	Name	Setting	Unit	Default
F2.00	Undervoltage Voltage(BUS)	400~500V	1V	440V
F2.01	Overvoltage Voltage(BUS)	500~700V	1V	650V
F2.02	Temperature sensor inspection	0: OFF(Pass the inspection) 1: ON	1	1
F2.03	Drive Temp. Protection	50.0~100.0℃	0.1℃	80.0℃
F2.04	Reserved	-	-	-
F2.05	Reserved	-	-	-
F2.06	Reserved	-	-	-
F2.07	Fan Start Mode	0: Start the fan once starts heating 1: Start the fan at pointed Temp.	1	0
F2.08	Fan Start Temperature	25.0~60.0℃	0.1℃	50.0℃
F2.09	Frequency Lower Limits	8.0kHz~F4.12	0.1kHz	10.0kHz
F2.10	Frequency Upper Limits	F4.11~32.0kHz	0.1kHz	28.0kHz
F2.11	Setting the Display Value on Main interface	0: Input cable Current 1: Output Power 2: Reserved 3: Power Setting 4: Reserved 5: Coil Current 6: Reserved 7: BUS Voltage 8: Drive Temp. 9: Reserved	1	0
F2.12	Load Inspection	0.00: OFF(Pass the inspection) 0.01~90.0: Detection sensitivity	0.01	0.01
F2.13	Protective self-recovery	0: OFF 1~10: Self-recovery Times(180s)	1	0
F2.14	Startup Time	0.5s~60.0s	0.1s	3.0s
F2.15	Shutdown Time	0.5s~60.00s	0.1s	3.0s
F2.16	Reserved	-	-	-
F2.17	Reserved	-	-	-
F2.18	Power curve detection time	0~600s	1s	60s
F2.19	Power curve rise time	0: OFF(Start immediately once power on) 1~6000: Power rising time	1s	0s
F2.20	Power curve starting power	10.0%~100.0%	0.1%	50.0%
F2.21	Reserved	-	-	-
F2.22	Reserved	-	-	-
F2.23	Reserved	-	-	-

5.3.4 F3 Setting

Function Parameter	Name	Setting	Unit	Default
F3.00	User's Password	****	1	0
F3.01	Factory's Password	****	1	0
F3.02	Reset to defaults	0: No Operation 2: Reserved 1: Load manufacture defaults	1	0
F3.03	Parameter Lock	0:Parameters modifications are allowed 1:Parameters modifications are forbidden Note: the above restrictions are invalid for this parameter	1	0
F3.04	Starting current	0.1A~Rating Current	0.1A	Model Setting
F3.05	Maintain current	0.1A~Rating Current	0.1A	Model Setting
F3.06	Time limitation	0~65535h	1h	0
F3.07	Heating Time	0~65535h	1h	0
F3.08	Power on Time	0~65535h	1h	0

5.3.5 F5 Communication Protocol

Function Parameter	Name	Setting	Unit	Default
F5.00	Local Address	0~200	1	1
F5.01	Communication baud rate selection	0: 1200bps 1: 2400bps 2: 4800bps3: 9600bps 4: 19200bps5: 38400bps	1	3
F5.02 F5.02	Data bit check Settings	0:No check(N,8,1)for RTU 1:even parity check(E,8,1)for RTU 2:Odd parity(O,8,1)for RTU 3:No check(N,8,2)for RTU 4:even parity check(E,8,2)for RTU 5:Odd parity(O,8,2)for RTU	1	0
F5.03	Communication response delay	0: No Delay 1~500ms	1ms	0
F5.04	Communication timeout	0.0: Invalid 0.1~200.0s	0.1s	0.0
F5.05	Communication timeout processing	0: No action 1: Stop Heating 2: Alarm and stop heating	0	1
F5.06	Reserved	-	-	-

5.3 Monitoring Parameters List

Monitoring Parameter	Name	Unit	Note
D0.00	Input Current (Factory default main interface)		
D0.01	BUS Voltage	1V	
D0.02	BUS Current	0.1A	
D0.03	Input cable Current	0.1A	
D0.04	Drive Temp.	0.1℃	
D0.07	Coil Temp.	0.1℃	
D0.11	Reversion Version		
D1.00	Input Current	0.1A	
D1.01	Output Current	0.1A	
D1.02	Output Frequency	0.1KHz	
D1.03	Output Power	0.01KW	
D1.04	Power Setting	0.01KW	
D1.08	Distance between coil and heating object		When full power, the distance between 15-25 is suggested

6 Operation Control

6.1 Control Mode list

Adjust Power Level by Keyboard (P0--P6)

X Terminal Startup, Adjust Power Level by Keyboard

X Terminal adjust the power Level

Adjust the power Level by Potentiometer/Adjust the power Level by Analog Value

X Terminal Startup, Adjust the power Level by Analog Value

6.1.1 Adjust the power Level by Keyboard

F0.01=15.15, Users can adjust the power level from P0 to P6.

6.1.2 X Terminal Startup, Adjust the power Level by Keyboard

F0.01=0.15, Drive turn on when X terminal connected, but no power output. Should move to P1 to start heating, users can adjust the power level from P0 to P6 by keyboard.

6.1.3 Adjust the power level by X TERMINAL

F0.01=0.00

Control Terminal and the relative Power:

X1-COM (20% of the rating power)

X2-COM (40% of the rating power)

X3-COM (60% of the rating power)

X4-COM (75% of the rating power)

X5-COM (80% of the rating power)

X6-COM (100% of the rating power)

6.1.4 Adjust the power by Potentiometer/Adjust the power by Analog Value

F0.01=2.02 Cable connection Terminal: VI1- GND

F0.02=3.03 Cable connection Terminal: VI2- GND

Note: Please set F0.02 on Dual Output Drives.

6.1.5 X Terminal Startup, Adjust the power by Analog Value

F0.01=0.02 Startup Terminal: X1-COM, Power control terminalVI1- GND

F0.02=0.03 Startup Terminal: X3-COM, Power control terminalVI2- GND

Note: Please set F0.02 on Dual Output Drives.

7 Fault Diagnosis and Countermeasures

7.1 Error Code and Description

Error code	Description	Reason analysis	Solutions
E001	Bus over current	1.Coil short circuit	Check if the coil burned or black somewhere; Check if the coil touched any metal object ; Check if any insulation layer is damaged and causes poor connections; If the coil can not be checked or repaired please change a new coil
		2.Output abnormal	Please remove the coil and turn on the Drive, if running ok means coil is fault. If still report E001 Please contact after sale service
E002	Overload 1	1.Coil short circuit	Check if the coil burned or black somewhere; Check if the coil touched any metal object ; Check if any insulation layer is damaged and causes poor connections; If the coil can not be checked or repaired please change a new coil
		2.Coil Output Terminal Spark	Please check if the output terminal or any connector loose, if any connector loose Please fasten it. Note: After terminal Spark, the wire connector will have oxidation phenomenon, Please cut off a section before reconnection
		3. Coil Spark Some Place	Check and repair the broken place, Please fine cover the broken place with high temp insulation materials
		4. Inductance of coil is too small	Disconnect the coil and power on the Drive (do not start with power level) if no E002 reported means coil inductance is too small. We suggest you test the inductance when making the coil until the inductance is with suggested range, or no e002 reported when turned on the machine Note: If the inductance too small, Drive will report E002 suddenly when start.

Error code	Description	Reason analysis	Solutions
E002	Overload 1	5. Over current protection parameters (F6.19--F6.32)setting value is too small	E002 reported during machine is running. Please check with keyboard to make sure E002 is reported under which frequency range , then adjust the frequency a little up as per the relation between over current protect parameters (F6.19--F6.32) and frequency until no E002 report. Warning: (DO NOT CHANGE THIS PARAMETERS UNTILL CONFIRMED WITH FACTORY)
		6. Insulation cotton is too thick	Adjust F2.12(Load-checking) . F2.12 value smaller when distance farer .If still can not meet the demand, Please reduce the thickness of the cotton.
		7.Some component of Drive damaged	Please contact UHY after sales service Note: IGBT/main board damaged
E003	Factory problem	No Drive model Matched	Reset the model as per actual model in F7.00
E004	Overload 2	1. Voltage unstable	Check the value of D0.01 (Bus voltage) via keyboard. When machine is working, the voltage should between 510--560V. F6.08(Bus voltage calibration) The value is smaller when Bus voltage is bigger.
		2. Unstable load current	Please select right coil cable as per the actual output current. Note: 1mm ² pass current about6A
E005	Self check fault	Drive problem	If report E005, Please restart the Drive, if still report E005, Please send the Drive back to factory for repair.
E006	Low voltage	1. Input electricity switch is fine or not	Test these values when machine is heating: 1. Drive terminal upside and down side voltage, check if these two voltage drop. 2. Check Drive input electricity to main board if normal.
		2. Input electricity voltage is normal or not	
		3. Connector of input electricity is loose or not	Please check if the terminal connectors too hot. Or Please fasten the terminal connectors.
		4. Rectifier bridge on Drive is fine or not	check the voltage of rectifier bridge input side(380V) and the output voltage (540V) , detailed value Please as per the parameters settings.
		5. Report E006 some hours after machine running	Check the fault as per above reasons.
		6. Error code E006 reported suddenly when machine turned on	Main board fault, Please change the main board and check again.

Error code	Description	Reason analysis	Solutions
E007	Drive temperature protection	1. when machine running ,the environment temperature is too high	Please low the machine temp. eg, add fans to blow it.
		2. Machine's ventilation not good	Please put the machine to the place with good air flow, and check if too much dust on the heat emission aluminum. Please clean the aluminum
		3. Cooling fan of the machine open circuit or damaged	Check if the cables connections and the fans all fine.
		4. F2.03 (Drive temperature) setting value is too low	Check if the parameters are all under right ranges. Please set them according to the actual situation. Please call service center for support.
		5. The air flow design is not good(air inlet and outlet)	Please change the air outlet design.
		6. Sensor misinformed	Check the sensor.
E008	Thermistor Protection	Coil temp too high	Please install fans for coil heat emission to make the coil temp under right range.
		2.F1.09(ratio of resistance and temperature) setting value too small	Adjust the F1.09 a bit bigger under the safety usage of the machine. Note: Thermistor is connected to terminal VI1 and VRF, F1.12(AI1 max Value) decided by machine sampling resistance, only confirmed the sampling resistance , then you can set the parameters of F1.09.
		3. Thermistor fault	Test the thermistor resistance under normal temp. if the value changes too much, Please do change the thermistor.
E009	Drive locked	Check F3.06 time limitation	Check the F3.06 value. Drive will stopped working when $F3.06 < F3.07$ Note: eg: when you want the machine stopped after 24H, setting method: $F3.06 = 24H + F3.07$
E010	Inner fault	Drive problem	Please reset the Drive, if can not solve the problem, please sent the Drive to factory for repair.

Error code	Description	Reason analysis	Solutions
E011	Load Error	1. inductance too big	if running light twinkles, Please check D1.02 (output frequency) , if the frequency no changes, Please remove some coil circles until the inductance within the right ranges, Please test the inductance with inductance bridges. Note: If the inductance not too big, you can increase the spacing of the circles.
		2. Coil connection error or open circuit	Check if the coil is open and check if the coil incorrect connected.
		3. Start current is too small	Check D1.18 (max. current) value under Drive NOT started. Check D1.01(output current) under running . Change F2.10(output frequency upside limitation) a bit smaller.
		4. The distance between coil and heating object is too big	change F2.12(load-testing) , value is smaller when distance is larger. Reduce the thickness of the cotton if necessary.
E012	Overload 3	Coil is shot	check the shot place carefully and cover the place with high-temp insulation materials. If can not found out the shot place Please change the coil.
E013	Reserved		
E014	Temp sensor fault	1. Temp sensor loose	Unplug the reinstall the temp sensor which connected to the main board.
		2.Temp sensor fault	change the temp sensor
E015	Communication fault	Communication fault	Contact UHY after sales service center to repair the Drive.
E016	Phase protection	1. Input voltage is too low	raise the input voltage to 320V-440V (normally the Bus voltage is 440V-650V) 。 Please mind the working voltage, then can analysis the parameters setting are reasonable or not. Note: During Drive is heating, The Bus voltage will lower then 420V if the input voltages lower then 300V. Alarms decided by the value set on F2.01.
		2. Input voltage is too high	decrease the input voltage to 320V-440V (normally the Bus voltage is 440V-650V) 。 Please mind the working voltage, then can analysis the parameters setting are reasonable or not. Note: During Drive is heating, The Bus voltage will higher then 650V if the input voltage higher then 440V. Alarms decided by the value set on F2.01.
		3. Inductance too large	Reduce the coil circles until no E016 reported; Reduce one more circle if necessary.
		4. The distance between coil and heating object is too small	Increase the distance between coil and heating object

Error code	Description	Reason analysis	Solutions
E016	Phase protection	5. Phase angle too small	During running, check the value of D1.08(phase angle is too small),increase the value of F7.20 (phase protection value)
E017	Reserved		
E018	Input lack phase	Input lack phase	Please check if the three phase input circuit cables are fine.
E019	Outside Fault		Outside electric fault, please check other components or electrics
E020	Bus over voltage	Input voltage too high	<p>Low the input voltage to 320V-440V (normally the Bus voltage is 440V-650V)。 Please mind the working voltage, then can analysis the parameters setting are reasonable or not. check the value of D0.01(Bus voltage) ,During Drive is running, the voltage should between 440V---650V. Note: adjust the parameter F6.08 (Bus voltage calibration)。 This Value is smaller when Bus voltage bigger.</p> <p>Note: During Drive is heating, The Bus voltage will higher then 650V if the input voltage higher then 440V. Alarms decided by the value set on F2.01. In the normal applications maybe have error code E016(phase protection) first, then twice shinning then have the error code E020</p>
E022	Heating object is too small		Please check the heating object
E023	Drive's fan error		
E024	Input Terminal Fault		
E025	Coil temperature sensor fault		Please check if temp sensor is loose or open.。
E026	No coil temp detected		Please contact service center for support
E027	Heating too long time		

7.2 FAQ and troubleshoot

(1) When powered on, the heating indicator flashes without output current.

Please check if the coil inductance too large.

Please check if the coil loose or fall down;

Please check if the heating Object is too small.

(2) After powered on, the Drive can heating, but power can not meet rating power, please check the following items.

Inductance too Small

During the machine running, check the value of D1.02 (output frequency), if the output frequency too high (bigger then 15), D1.03 (output power) can not reach the rating power, that means inductance adaptation had some problems. We advise you add some circles. Then turn on the machine and check D1.02, D1.03 until the Drive can heating with full power.

Inductance too Big

If the inductance too big, phase protection will ON. Please remove some circles or farer heating distance but we not suggest the distance farer then 3cm.

Input Frequency Limit:

During the machine running, check the value of D1.03 (output power) and D1.02 (output frequency), and F2.09 (output frequency lower limit) to check if frequency be limited. If D1.02 is very near F2.09, Please change the value of F2.09 smaller, but can not smaller then 10.

Heating material makes power derating

If heating Object can not be induction heated or have any problems. Please communicate with customer and tell customer that under such material, power will drop. If can change the material, we suggest to change another material.

Output current limited

During the machine running, check the value of D1.03 (output power) is full or not? D1.01 (output current), and the value of D1.18 (max IO current), if the two value the same, that means current limited. Please

change the F6.19 and F6.32 bigger. F6.19=F6.32, we suggest add 0.3 maximum.

Note: When change the parameter on F6.XX and above, please contact after sale service center for support.

Startup Terminal connection Fault

Check the fixed value of F0.01 as per the parameters function definition, and check if the terminals connections right or not.

The heating distance is too far

During the machine running, check the value of D1.01 (output current), D1.02 (output frequency), D1.03 (output power), D1.08 (phase angel), to fix what is the problem, If D1.08 very large, eg, 30/40, and D1.03 can not meet rating power, In this case D1,01 will very large. Please change the heating distance smaller. Better distance should within 2-3cm.

The heating distance is too near

During the machine running, check the value of D1.08 (phase angel), IF D1.08 about 10, Please farer the heating distance. Better distance should within 2-3cm.

(3) Air-switch cut when turn on

Check if any short circuit among the input power supplies (RST) to eliminate any problems.

Check if the rectifier bridge has broken down. If damaged, please contact service center.

(4) Air-switch Cut when Heating.

Check if the Coil Spark.

Check if the Coil has any electric leakage.

8 Attached Table for Recording Real-time Operation Data of Induction Drive

Test Date:

Mode of the Drive:

Coil Cable Size : mm²

Inductance with Load under house temp: μH

Heating Distance: cm

Environment Temp. °C

Record the following Parameter when Heating with Full Power:

Code	Name	Startu p 0 min	Heating 15 min	Heating 30 min	Heating 45 min	Heating 60 min	Heating 90 min	Heating 120 min
D0.01	BUS Voltage							
D0.02	BUS CURRENT							
D0.03	Input cable Current							
D0.04	Drive Temp.							
D0.06	Heating Object Temp.							
D0.07	Coil Temp							
D1.01	Output Current							
D1.02	Output Frequency							
D1.03	Output Power							
D1.04	Power Setting							
D1.08	Heating Distance							
Current tested by clamp meter								
Voltage								
Coil Temp. tested by Meter								